

## LIMITED WARRANTY

The DS-224 is warranted against defects in workmanship and materials for two years from date of sale. This warranty does not apply to damage resulting from accident, misuse, or alteration nor where connected voltage is more than 10% above the configured operating voltage, nor to equipment improperly installed or wired or maintained in violation of this Owner's Manual. No other written or oral warranty applies. No employee, agent, dealer or other person is authorized to give any warranties on behalf of ASE.

The customer shall be responsible for all costs incurred in the removal or reinstallation and shipping of the product for repairs. Within the limitations of this warranty, inoperative units should be returned, freight prepaid, to ASE, and we will repair or replace, at our option, at no charge to you with return freight paid by ASE. It is agreed that such repair or replacement is the exclusive remedy available from ASE and that ASE IS NOT RESPONSIBLE FOR DAMAGES OF ANY KIND, INCLUDING INCIDENTAL AND CONSEQUENTIAL DAMAGE. Some states do not allow the exclusion or limitation of incidental or consequential damages so the above exclusion may not apply to you. The warranty gives you specific legal rights, and you may also have other rights which vary from state to state.



**AUTOMATED SYSTEMS ENGINEERING, INC.**  
2519 E SAINT VRAIN ST  
COLORADO SPRINGS, COLORADO 80909  
PHONE: 719-599-7477 FAX: 719-599-7482  
Visit us on the Internet at: [www.goase.com](http://www.goase.com)



**CAUTION:** Read all instructions carefully before installation.  
Save this Installation Manual for future reference.

# DS-224

## RAIN/SNOW SENSOR CONTROLLER INSTALLATION MANUAL

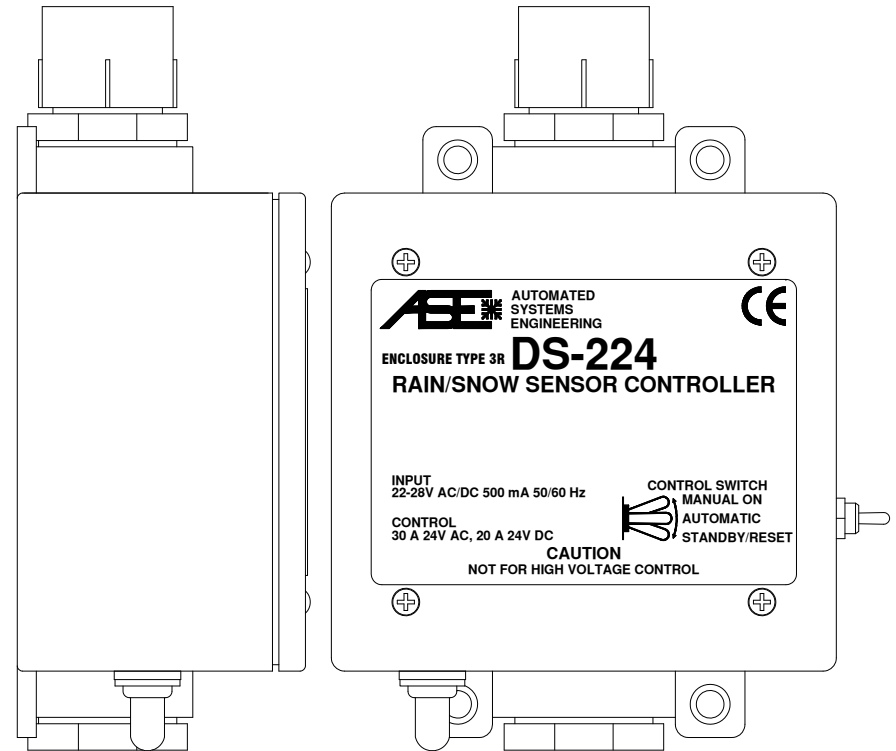

Manufactured By



**AUTOMATED  
SYSTEMS  
ENGINEERING**

2519 East Saint Vrain St Colorado Springs, Colorado 80909

## General Safety Instructions

1. **THIS UNIT SHOULD BE INSTALLED, OPENED, AND REPAIRED BY QUALIFIED PERSONNEL ONLY!**
2. To avoid shock hazard do not open the front cover with power connected to the DS-224 or any controlled equipment.
3. Limit input voltage to 22-28 VAC/VDC.
4. Replace fuse F1 with a 2 Amp 32 V or 250 V 3AG fast acting fuse ONLY.

## Selecting a Mounting Location for the DS-224

The interleaved grid on the top of the DS-224 is the precipitation sensor or "moisture grid." The rubber "boot" protruding from the bottom of the enclosure is the temperature sensor. For reliable rain and snow detection the unit must be mounted in a location that exposes the moisture grid to a clear view of the sky. The unit should not be mounted directly under eaves or overhangs. It should not be mounted so close to the ground that it may become buried in snow. For proper temperature detection the DS-224 must be mounted outdoors, away from furnace vents, dryer vents, and other sources of heat. Note that, when powered, the DS-224 moisture grid will always remain hot. This is normal. This allows the grid to continuously melt snow and evaporate both rain and snow from the grid.

The DS-224 can be mounted by screwing the base conduit hub onto an appropriate size free-standing conduit or by using the mounting holes in each corner of the enclosure.

### DO NOT DRILL HOLES THROUGH THE ENCLOSURE FOR MOUNTING!

This can allow water into the enclosure causing a potential shock or fire hazard. It is recommended that a weatherproof conduit or junction box be mounted below the DS-224 for termination of the power and load pigtails to the building wiring.

### ALWAYS USE CARE WHEN REPLACING THE ENCLOSURE FRONT COVER!

Be sure the front cover gasket is not pinched or rolled. Do not overtighten the front cover screws.

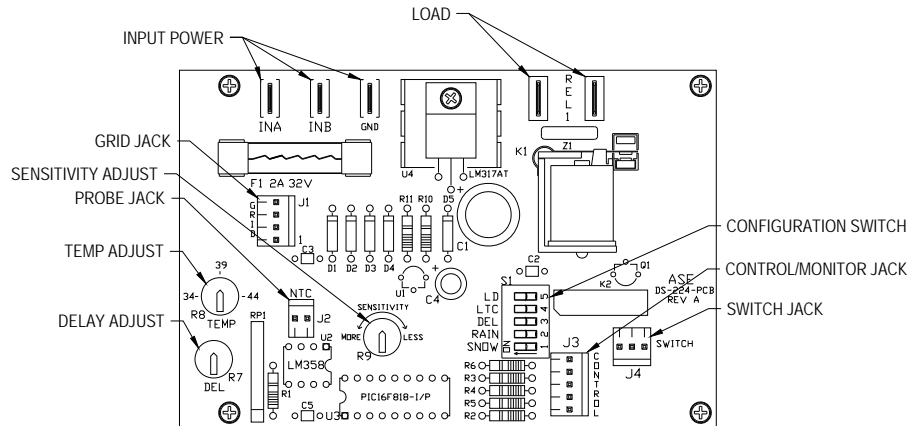

## External Control/Monitor Operation

Pin	Color	Function
1	Green	Standby/Reset
2	Black	Manual On
3	Orange	Deice On Mon
4	Red	Deice On Mon
5	White	Return

An external control/monitor jack is provided on the DS-224. Order the optional CS-1 control/monitor cable to access this feature. Connecting Black to White will activate the "Manual On" function. Connecting Green to White will activate the "Standby/Reset" function. The Red/Orange leads are connected to an internal low power monitor relay. This relay, rated at 24 VAC/VDC at 400 ma, will close with the load relay and can be used to externally monitor activation of the sensor.

## Preseason Snow Detection Testing

It is always a good idea to test the operation of the DS-224 prior to the winter season. Procure some clean water and, if the outdoor temperature is above the trigger point, a can of spray component cooler (Radio Shack Part #64-4321 or equivalent.) Clean the moisture grid following the procedure outlined above and allow it to dry. Apply power to the DS-224 and drip some of the water onto the moisture grid, and then spray the temperature sensor protruding from the base of the enclosure with the component cooler. Once the temperature sensor has reached the trigger point with water still present on the grid the DS-224 will activate. The user should hear the internal control relay close. Proper operation has been confirmed. Allow the grid to dry completely. To clear the Delay-Off timer place the override switch into "Standby/Reset", and then back to the "Automatic" position.

*Need Indoor Monitoring & Control?  
Take a Look at the ASE CDP-2*



Compatible with the DS-224  
Simple Installation & Operation at a Competitive Price  
Visit [www.goase.com](http://www.goase.com) for more information

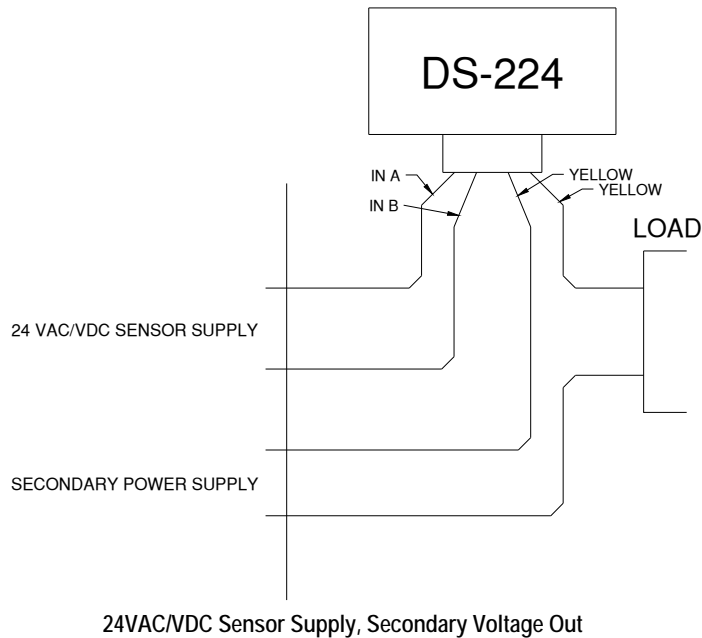

24VAC/VDC Sensor Supply, Secondary Voltage Out

These are just some of the possible wiring schemes that can be used to connect the DS-224 to your load for control. Remember, these are only suggestions. **You should always check with a qualified electrician to insure conformance with local electrical codes!**

### Moisture Grid Maintenance & Replacement

It is recommended that the DS-224 be powered down and the grid wiped clean with clear water at least once every 4 months. Heavy deposits may be removed using Scotch-Brite. However, after a number of years, the corrosive elements left behind when water is evaporated out of the moisture grid will eventually damage the grid rings. The moisture grid can be easily replaced by ordering and installing an MG-4 "Moisture Grid Assembly" and following the procedure below:

#### THIS PROCEDURE SHOULD ONLY BE PERFORMED BY QUALIFIED PERSONNEL!

Open all power and load supplies connected to the DS-224. Open the front cover and remove the moisture grid cable from the Grid Jack. While holding the reducing bushing, unscrew and remove the old moisture grid. Install the supplied thread sealing tape to the threads of the new moisture grid, place the new grid into the top hole and screw the assembly into the reducing bushing. Tighten the grid hand tight plus ¼ turn. This will properly seat the rubber sealing ring. Reconnect the new cable to the Grid Jack. Confirm that the four connector pins are properly aligned with the jack. Close the front cover, confirming that the front cover gasket is properly sealed. Reapply power.

#### ALWAYS USE CARE WHEN REPLACING THE ENCLOSURE FRONT COVER!

Be sure the front cover gasket is not pinched or rolled. Do not overtighten the front cover screws.

### Setting the Configuration Switches and Adjustments

The following table outlines the operating modes for the DS-224 and explains the functions of the adjustments. Trigger temp (TT) is adjustable from 34°F-44°F using the "Temp Adjust" control. When ambient air temperature (AT) is below this trigger point precipitation is assumed to be snow. When above this temperature, precipitation is assumed to be rain. The SNOW switch will cause the sensor to activate when snow is detected. The RAIN switch will cause the sensor to activate when rain is detected.

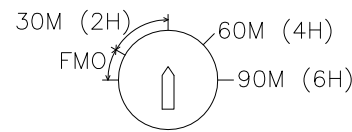
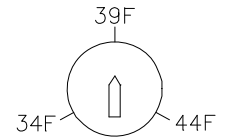

The DEL configuration switch activates the "Delay Off" drying cycle timer on the DS-224. The timer allows the DS-224 to dry the heated surface through evaporation once precipitation has stopped. The drying cycle reduces the chance of moisture left behind refreezing into ice. The Long Delay (LD) configuration

switch determines the time span of the drying cycle. LD off sets a 30-90 minute span. LD on sets a 2-6 hour span. This timer is restarted by each precipitation detection. Therefore, the DS-224 will continue to operate as long as precipitation is detected, then for the Delay Off period once precipitation has stopped. All "sensor" modes (DEL off) provide a 2 minute closure to reduce cycling of an external controller. When in "controller" mode (DEL on) the Delay Off time can be adjusted from 30-90 minutes (LD Off) or 2-6 hours (LD On) using the "Delay Adjust" control. Note the "Forced Manual On" function at the low end of the Delay Adjust control. The relay will close when this area is entered and open when exited. Only use the "Forced Manual On" function for testing. Never leave the Delay Adjust control near the "Forced Manual On" area during normal operation.

The Low Temperature Cutoff (LTC) option is typically used on snow melting systems with limited output capacity. If selected, the sensor will not trigger if precipitation is initially detected below 15°F. However, if the deicing system has been activated, precipitation continues, and the ambient temperature drops below 15°F, LTC will be ignored. This assures that water on the surface from melting snow will not immediately refreeze into ice as a result of deactivating the deicing system.

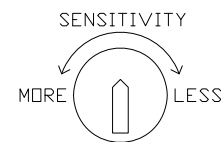

The DS-224 precipitation sensor can detect even a single snow flake or rain drop. However, if the DS-224 is mounted in an area susceptible to high winds, dripping condensation, or blowing ground snow, nuisance triggering of the sensor may occur. While proper placement is the best remedy, the Sensitivity control can also be used to reduce nuisance triggering. An internal timer checks the precipitation sensor for moisture once per second and keeps a running count of the number of continuous seconds the grid is triggered. The highest sensitivity setting (toward More) requires 3 seconds of continuous precipitation detection before the unit triggers. The lowest sensitivity setting (toward Less) requires a full 4 minutes of detection before the unit triggers. If a trace amount of snow blows onto the grid from a drift or overhang it will likely be melted and evaporated within 1-2 minutes. Similarly, a very light snowfall may also clear quickly from the grid. If these conditions should be ignored by the sensor the Sensitivity control can be adjusted as required. However, to prevent non-triggering during a true event, it is recommended that **the user start at highest sensitivity (More), then adjust while monitoring operation over time.**

**POWER MUST BE CYCLED FOR CONFIGURATION SWITCH CHANGES TO TAKE EFFECT**

## Recommended Switch Settings by Function

Function	Trigger	LD Off	LD On	LTC	DEL	RAIN	SNOW
Snow sensor w/o LTC	TT>AT	2 Min	2 Min	OFF	OFF	OFF	ON
Snow sensor w/LTC	TT>AT>15°F	2 Min	2 Min	ON	OFF	OFF	ON
Snow controller w/o LTC	TT>AT	30-90 Min	2-6 Hr	OFF	ON	OFF	ON
Snow controller w/LTC	TT>AT>15°F	30-90 Min	2-6 Hr	ON	ON	OFF	ON
Precipitation sensor	Not Used	2 Min	2 Min	X	OFF	ON	ON
Precipitation controller	Not Used	30-90 Min	2-6 Hr	X	ON	ON	ON
Rain sensor	AT>TT	2 Min	2 Min	X	OFF	ON	OFF
Rain controller	AT>TT	30-90 Min	2-6 Hr	X	ON	ON	OFF

## Fine Adjustment for Efficient Operation

The DS-224 is shipped with the TEMP and DEL adjustments in the center position, representing 39°F (3.9°C) and 30 minutes of Delay-Off time respectively. The Sensitivity control is set for highest sensitivity. Depending on local conditions the user may find that fine adjustment of the controls may provide more satisfactory operation. If the sensor does not trigger during very wet snows the trigger temperature may need to be adjusted higher. Conversely, if the user notices false triggers during cold rains that do not freeze, the trigger temperature may need to be lowered. Locations susceptible to blowing ground snow or snow falling from eaves or trees may benefit from a lower sensitivity adjustment. The Delay-Off time can also be adjusted or the range expanded using the LD configuration switch to provide clean melt-off without excessive running time. Fine adjustment can both save operating expense and provide more reliable operation. However, to keep reliability high, always make adjustments in small increments.

### ALWAYS USE CARE WHEN REPLACING THE ENCLOSURE FRONT COVER!

Be sure the front cover gasket is not pinched or rolled. Do not overtighten the front cover screws.

## Manual Override Switch Operation

An override switch mounted on the side is provided for testing and special operational requirements. Placing the switch in the "Automatic" position will allow the sensor to operate normally, activating the controlled equipment as needed. Placing the switch in "Manual On" will close the load relay, activating the controlled equipment. The "Standby/Reset" position prohibits triggering of the unit, clears any active delay timer, and opens the load relay. In order to reduce excessive runtime for the heater the "Manual On" mode will remain in effect for a maximum of 40 hours, then return to "Automatic" mode even if the switch is still in the "Manual On" position. You may put the DS-224 back into "Manual On" mode by switching to "Automatic", then back to "Manual On". This will restart the 40 hour timer.

If the override switch is placed in "Manual On" for less than 2 seconds, then switched back to "Automatic" the controller will execute one delay off cycle. This can be used to clear a frost or hail buildup without the danger of leaving the system in a continuous "Manual On" condition. "Standby/Reset" can still be used to clear this delay off cycle.

## Typical Wiring

The sensor supply voltage can be in the range of 22-28 VAC/VDC. The supply input leads (IN A and IN B) are not polarity sensitive and can be connected to either polarity of a DC supply. A standard 24VAC 20VA HVAC-type transformer will supply enough power for the DS-224 and an optional CDP-2 indoor control/display panel.

The two load leads of the DS-224 do not supply power directly to your load. The relay inside the DS-224, like a switch or thermostat, is used to switch a voltage of your choice. While not as convenient as directly supplying power for the load this allows you to operate the DS-224 from one voltage while controlling a load of a different voltage without adding an external relay or contactor. For example, the DS-224 can be powered from 24VAC but can directly control a 12VDC signal for a contactor coil or can operate from 24VAC and provide a dry contact thermostat-style closure for a boiler. The following diagrams show some possible wiring schemes for connecting the DS-224 to your load. For clarity the GROUND lead is not shown.

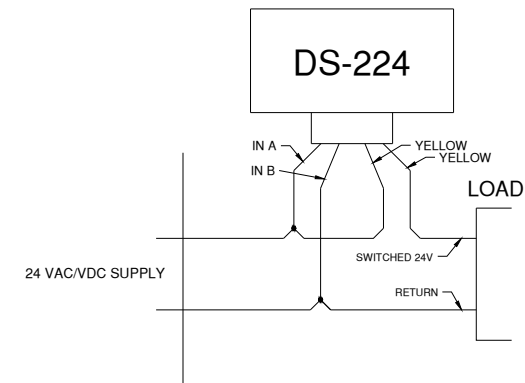

24VAC/VDC Sensor Supply, Supply Voltage Out

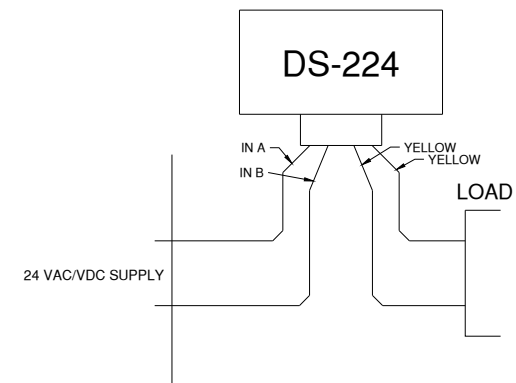

24VAC/VDC Sensor Supply, Dry Contact Thermostat-Style Control